

**Biomass Combined
Heat and Power
Demonstration Project**

North Country Hospital (NCH) Overview

- Critical Access Hospital (CAH) located near the Canadian Border in Vermont
- Of Vermont's 14 hospitals, NCH is 5th largest by annual revenue (\$92M)
- Yet, NCH has lowest overhead expenses as % total operating expenses (19.6%)
- Serves two of the most rural & poorest counties in Vermont
- Average annual capital budget is approximately \$3.5M



- Medical Campus of 35 acres
- Main hospital building is 121,000 SF
- Annual #2 fuel oil consumption 201,000 gallons
- Ave monthly electrical consumption of 310,065 kWh



- 500-hp 300-psi Hurst Boiler
- 265 kW Elliot Steam Turbine
- 400-Ton Trane Steam-Fired Absorption Chiller
- C-14 Chiptec Gasifier (14 MBTU)

Woodchip Bin Stores Approximately 40 Tons



Project Steam Turbine Assembly



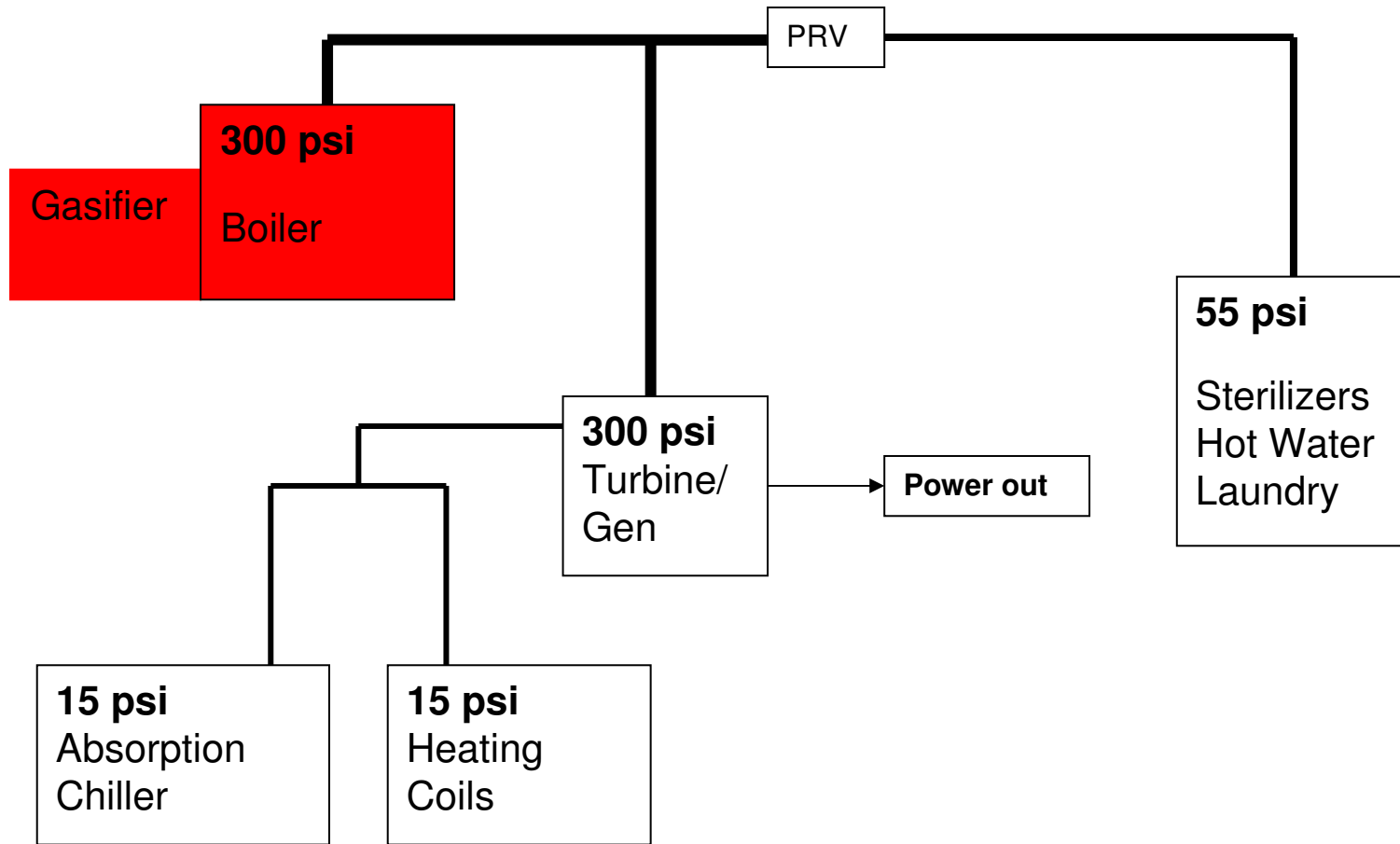

Projected vs Actual

- Initially Projected Construction Costs \$1.2M
- Projected ROI of 21%
- Projected payback of 4.8 years with fuel oil at \$1.00/gallon
- Projected wood fuel costs \$10/ton
- Actual Construction Costs w/ incremental chiller \$1.67M
- Actual ROI 18%
- Actual payback of 5.5 years with fuel oil at \$2.00/gallon
- Actual Ave wood fuel costs \$28/ton

Do's

- Get a third party feasibility study
- Determine whether a fuel switch project fits into the timeline of your institution's Strategic Space Master Plan regarding renovations and infrastructure replacement schedules
- Gain solid internal support from senior leadership
- Apply for Federal/State grants when possible- try to bring cash to the table
- Partner with a credible and reliable fuel supplier **BEFORE** you perform a feasibility study

Do's contd..

- Make sure your construction budget includes at least 30% contingency
- Budget between 0.5 and 0.75 FTE of highly qualified maintenance personnel (preferably at master level)
- Be certain to build in adequate working capital in operations budget to cover unexpected failures and premature wear of key components
- Provide adequate automation controls and metering capabilities

Don't

- Hire an engineering firm that lacks BCHP design experience—Follow up and speak with references- particularly site management and repair personnel
- Think money is free...it's not...you have to manage the system to maximize your savings
- Assume the energy landscape will be easy to track— electrical, fuel and wood prices fluctuate making it hard to track project savings over time
- Underestimate the importance of environmental permitting- budget accordingly



Considerations

- Sole source to those construction groups you trust—don't just accept low bidder
- If you can't sole source, then build liquidity damages into your contract for savings lost due to timeline interruptions
- Incentives for operators

Additional Information



- <http://www.nrbp.org/publications/default.htm>
- Jeff Forward: forward@gmavt.net
- Terry Robbins: terry.robbins@uvm.edu